

# BIRMINGHAM WATER WORKS

July 23, 2024

Bid: 24-03-07

Subject: Invitation to Bid

Prospective Bidders:

Sealed bid packages for Curb Boxes, Valve Boxes, and Pavadjusters will be received in the Purchasing Department of the Birmingham Water Works Board, located at 3600 First Avenue North, Birmingham, Alabama 35222, until 10:00 a.m. (CST), Thursday, August 1, 2024, at which time and place they will be publicly opened and read. All potential suppliers must receive an executed copy of the applicable Receipt of Bid Package from the BWW Purchasing Department before their bid package may be considered responsive, pending evaluation of appropriate staff.

"Specifications and Conditions" and "Bid Forms" are attached, and all bids shall be F.O.B. destination, freight prepaid, and at no charge. One copy of the bid form should be returned, and the bidder should retain a copy.

The Board reserves the right to reject any bids submitted or waive any informalities and technicalities. The Board reserves the right to select one or more suppliers for the award by way of awarding all items to one supplier, individual line items to one or more suppliers, or subcategories of products/services to one or more suppliers, when to do so, is in the best interests of the Board. The Board reserves the right to award the bid on an individual or total cost of bid basis. The Board reserves the right to cancel this bid within thirty (30) days with written notice.

The Board reserves the sole right to award contracts to the lowest responsive and responsible supplier(s) as described in the solicitation documentation. The initial term of the contract shall be for a period of one (1) year from the date of award, and prices quoted shall remain effective for that period. The Board reserves the sole right to extend any applicable contracts for additional one (1) year periods or as allowable per State of Alabama law. The Board reserves the right to cancel the contract due to non-satisfactory performance or if the awarded supplier is found to violate the terms and conditions or does not correct any violations of specifications within two days after giving notice. The Board reserves the right to RE-BID. The Board reserves the right to enter into a month-to-month contract once the contract has ended, at the current prices, until the next bid has been awarded with the mutual consent of applicable parties.

All bid packages must be hand-delivered to the BWW Purchasing Department, which is located at 3600 First Avenue North, Birmingham, Alabama 35222. The bid packages must be directed to the attention of the Purchasing Superintendent and marked in the lower left-hand corner of the envelope as follows: "Bids for "Curb Boxes, Valve Boxes, and Pavadjusters due on Thursday, August 1, 2024, at 10:00 a.m. (CST)" at which time and place they will be publicly opened and read.

Cordially,



Jonathan Jett,  
Purchasing Superintendent



**Solicitation Name: Curb Boxes, Valve Boxes, and Pavadjusters**

**Solicitation Number: 24-03-07**

**1. Introduction**

**1.1. Purpose of Procurement**

Pursuant to State of Alabama Code § 41-16-54 this solicitation request is being issued to establish a contract with one or more qualified suppliers who will provide **Curb Boxes, Valve Boxes, and Pavadjusters** to the Birmingham Water Works (hereinafter, "the BWW") as further described in this solicitation.

The BWW reserves the right to purchase from the any State of Alabama contract or an approved cooperative purchasing agreement if it is more economical and/or in the BWW's best interest.

**1.2. Overview of the Solicitation Process**

The objective of the solicitation is to select one or more qualified suppliers (as defined by Section 1.1 "Purpose of the Procurement") to provide the goods and/or services outlined in this solicitation to the BWW. This solicitation process is being conducted to gather and evaluate responses from supplier(s) for potential award(s). All qualified suppliers are invited to participate by submitting responses, as further defined below.

NOTE TO SUPPLIERS: The general instructions and provisions of this document have been drafted with the expectation that the BWW may desire to make one award or multiple awards. For example, this document contains phrases such as "contract(s)" and "award(s)". Please refer to Section 1.1 "Purpose of the Procurement" and Section 6.6 "Selection and Award" for information concerning the number of contract awards expected.

**1.3. Schedule of Events**

The schedule of events set out herein represents the BWW's best estimate of the schedule that will be followed. However, delays to the procurement process may occur which may necessitate adjustments to the proposed schedule. If a component of this schedule, such as the close date, is delayed, the rest of the schedule may be shifted as appropriate. Any changes to the dates up to the closing date of the solicitation will be publicly posted prior to the closing date of this solicitation. After the close of the solicitation, the BWW reserves the right to adjust the remainder of the proposed dates, including the dates for evaluation, award, and the contract term on an as needed basis with or without notice.

| Description   | Date                                | Time              |
|---|-------------------------------------|-------------------|
| Release of Solicitation   | As published per state law.         | N/A               |
| Deadline for written questions sent via email to the Issuing Officer referenced in Section 1.4. | N/A                                 | N/A               |
| Bidders/Offerors' Conference<br>Location: <b>None</b>   | N/A                                 | N/A               |
| Responses to Written Questions  | N/A                                 | N/A               |
| Bids Due/Close Date and Time  | <b>Thursday, August 1, 2024</b>     | <b>10:00 a.m.</b> |
| Bid Evaluation Completed (on or about)  | One to Two Weeks after Close Date   | N/A               |
| Finalize Contract Terms   | Two to Three Weeks after Close Date | N/A               |



#### 1.4. Official Issuing Officer (Procuring Agent)

Jonathan Jett

Jonathan.Jett@bwwb.org (email address)

#### 1.5. Definition of Terms

Please review the following terms:

- Awarded Supplier- The supplier with whom the BWW will source products and/or services from as a result of the awarded contract and/or BWW issued PO
- Birmingham Water Works Board – the governmental entity identified in Section 1.1 “Purpose of Procurement” of this solicitation
- Birmingham Water Works Nine Member Voting Board of Directors- The awarding authority for BWW.
- Board- Birmingham Water Works Nine Member Voting Board of Directors
- Contract Amendment Form- a BWW issued document that adds, deletes, corrects, and/or modifies items such as contract extensions, terms revisions, increase or decrease of commodities, assignments, delegations of approval bodies, etc...
- Historically Underutilized Business- A business formed for the purpose of making a profit and is at least 51% owned, operated and/or controlled by one or more American citizens or permanent resident aliens who are: Minority Business Enterprise (MBE); Women's Business Enterprise (WBE); Disadvantaged Business Enterprise (DBE) and Disable Veteran Business Enterprise (DVBE); (herein sometimes collectively referred to as HUB)
- HUB Forms- Any document that captures information to determine if a company has received the verifiable status of Minority Business Enterprise (MBE), Women's Business Enterprise (WBE), Disadvantaged Business Enterprise (DBE), or Disable Veteran Business Enterprise (DVBE). All HUB Forms are verified and approved by the Birmingham Construction Industry Authority
- Supplier(s) – companies desiring to do business with the BWW

#### 1.6. Contract Term and Renewal

Award shall be made to the lowest responsive and responsible supplier(s) as described in Section 6 of this document. The initial term of the contract shall be for a period of one (1) year from date of award and prices quoted shall remain effective for that period. The Board reserves the sole right to extend any applicable contract(s) for additional one (1) year periods or as allowable per State of Alabama law.

**All contract renewals must be approved by the Board. Before the contract end date, the BWW shall submit a Contract Amendment Form to the awarded supplier(s). The Contract Amendment Form may include any mandatory or implicative contract changes from BWW**

## 2. Instructions to Suppliers

By submitting a response to the solicitation, the supplier is acknowledging that the supplier:

1. Has read the information and instructions,
2. Agrees to comply with the information and instructions contained herein.

### 2.1. General Information and Instructions

#### 2.1.1. Restrictions on Communicating with BWW Personnel

From the issue date of this solicitation until the award is approved by the Birmingham Water Works Nine Member Voting Board of Directors, suppliers are not allowed to communicate for any reason with any BWW Personnel except through the Issuing Officer named herein, the Issuing Officer's



designee, or during the Bidders/Offerors' conference (if any), or as defined in this solicitation or as provided by existing contract(s). Prohibited communication includes all contact or interaction, including but not limited to telephonic communications, emails, faxes, letters, or personal meetings, such as lunch, entertainment, or otherwise. The BWW reserves the right to reject the response of any supplier violating this provision.

**2.1.2. Attending Bidders/Offerors' Conference**

The Bidders/Offerors' conference or any other information session (if indicated in the schedule of events) will be held at the offices referred to in Section 1.4 "Schedule of Events". Unless indicated otherwise, attendance is not mandatory, although suppliers are strongly encouraged to attend. However, in the event the conference has been identified as mandatory, then a representative of the supplier must attend the conference in its entirety to be considered eligible for contract award. The supplier is strongly encouraged to allow ample travel time to ensure arrival in the conference meeting room prior to the beginning of any mandatory conference. The BWW reserves the right to consider any representative arriving late to be "not in attendance." Therefore, all suppliers are strongly encouraged to arrive early to allow for unexpected travel contingencies.

**2.1.3. BWW's Right to Request Additional Information - Supplier Responsibility**

Prior to an award, the BWW must be assured that the selected supplier has all of the resources to successfully perform under the contract. This includes, but is not limited to, adequate number of personnel with required skills, availability of appropriate equipment in sufficient quantity to meet the on-going needs of the BWW, financial resources sufficient to complete performance under the contract, and experience in similar endeavors. If, during the evaluation process, the BWW is unable to assure itself of the supplier's ability to perform, before award, the BWW shall have the option of requesting from the supplier any information deemed necessary to determine the supplier's responsibility. If such information is required, the supplier will be so notified and will be permitted approximately seven (7) business days to submit the information requested.

**2.1.4. Failing to Comply with Submission Instructions**

Responses received after the identified due date and time or submitted by any other means than those expressly permitted by the solicitation will not be considered. Responses must be complete in all respects, as required in each section of this solicitation.

**2.1.5. Rejection of Responses; BWW's Right to Waive Immaterial Deviation**

The BWW reserves the right to reject any or all responses, to waive any irregularity or informality in a response, and to accept or reject any item or combination of items, when to do so would be to the advantage of the BWW. It is also within the right of the BWW to reject responses that do not contain all elements and information requested in this solicitation. A response will be rejected if the response contains any defect or irregularity and such defect or irregularity constitutes a material deviation from the solicitation requirements, which determination will be made by the BWW on a case-by-case basis.

**2.1.6. BWW's Right to Amend and/or Cancel the Solicitation**

The BWW reserves the right to amend this solicitation. Any revisions will be made in writing prior to the solicitation closing date and time. By submitting a response, the supplier shall be deemed to have accepted all terms and agreed to all requirements of the solicitation (including any revisions/additions made in writing through an addendum posted by BWW, prior to the close of the solicitation whether or not such revision occurred prior to the time the supplier submitted its



response. THEREFORE, EACH SUPPLIER IS INDIVIDUALLY RESPONSIBLE FOR REVIEWING THE REVISED SOLICITATION AND MAKING ANY NECESSARY OR APPROPRIATE CHANGES AND/OR ADDITIONS TO THE SUPPLIER'S RESPONSE PRIOR TO THE CLOSE OF THE SOLICITATION. The BWW reserves the right to cancel and if desired, re-advertise this solicitation at any time.

**2.1.7. Costs for Preparing Responses**

Each response should be prepared simply and economically, avoiding the use of elaborate promotional materials beyond those sufficient to provide a complete presentation. The cost for developing the response and participating in the procurement process is the sole responsibility of the supplier. The BWW will not provide reimbursement for such costs.

**2.1.8. Quantities or Estimates of Products and Services**

The quantities specified herein are estimates based upon current consumption and projected demand for the next contract year and shall not be construed to represent an amount which the BWW shall be obligated to utilize or purchase. The exact amounts ordered may be more or less and subject to BWW's actual needs. The responding supplier acknowledges and agrees that the BWW will only be responsible for the commodities and/or services actually purchased and/or consumed.

**2.1.9. Permits and Licensing**

The awarded supplier shall be responsible for obtaining all permits, licenses, certifications, bonds, etc., required by federal, state, county, and municipal laws, regulations codes, and ordinances for the performance of the work required in these specifications and to conform to the requirements of said legislation. All fees must be included in the contract amount and paid by the awarded supplier.

**2.1.10. Use of Subcontractor(s)**

Except as may be expressly agreed to in writing by the BWW, the awarded supplier shall not subcontract, assign, delegate, or otherwise permit anyone other than the supplier's personnel to perform any of supplier's obligations under the executed contract.

No subcontract which the awarded supplier enters into with respect to performance of obligations or work assigned under the BWW awarded contract shall in any way relieve the supplier of any responsibility, obligation, or liability under the contract which may be awarded from this solicitation.

All restrictions, obligations, and responsibilities of the supplier under the awarded contract shall also apply to any subcontractor(s) that may be sourced by the supplier. Any contract with a subcontractor must preserve the rights of the BWW. The BWW shall have the right to request the removal of a subcontractor from the awarded contract with or without cause.

**2.1.11. Supplier Performance**

In the event the BWW deems it expedient to perform service(s) or source alternate similar/like products(s) which have not been provided by the supplier as required by the awarded contract, or to correct work which has been inadequately performed by the supplier as required in the solicitation documents, BWW reserves the sole right to procure services and/or products from another source and may charge the difference between the contract and the substitute contract to the defaulting supplier.

The BWW reserves the right to inspect the manufacturing and/or service development process of any awarded supplier's products and/or services.



### **2.1.12. Supplier Warranties**

The awarded supplier represents and warrants that the goods and services provided in accordance with this solicitation will appear and operate in conformance with the terms and conditions of the finalized contract.

All goods delivered by awarded supplier to the BWW shall be free from any defects in design, material, or workmanship. If any goods offered by the awarded contractor are found to be defective in material or workmanship, or do not conform to supplier's warranty, the BWW shall have the option of returning, repairing, or replacing the defective goods at awarded supplier's expense. Payment for goods shall not constitute acceptance. Acceptance by the BWW shall not relieve the awarded supplier of its warranty or any other obligation under the finalized contract.

The awarded supplier represents and warrants that title to any property assigned, conveyed or licensed to the BWW is good and that transfer of title or license to the BWW is rightful and that all property shall be delivered free of any security interest or other lien or encumbrance.

The awarded supplier represents and expressly warrants that all aspects of the goods and services provided or used by it shall at a minimum conform to the standards in the supplier's industry. This requirement shall be in addition to any express warranties, representations, and specifications included in the finalized contract, which shall take precedence.

### **2.1.13. Priority Customer Status**

By submitting a Cost Worksheet response to this solicitation, supplier understands and acknowledges that the BWW provides water services that are essential to the health and welfare of the public. Failure of an awarded supplier to provide materials under any awarded contract issued pursuant to this solicitation may jeopardize the BWW's ability to provide timely services, which may affect the health and welfare of the public served by the BWW. In the event of product shortages at any level of the production to delivery chain, awarded supplier(s) agrees and affirms that the BWW will be given the earliest possible notice of supply chain issues and the highest priority for allocation of the item(s) listed herein. To the extent that awarded supplier(s) must prioritize and/or allocate delivery among its customers, the requirements of the BWW will be honored before contract items are provided to a customer with no obligations with regard to the public health and welfare.

### **2.1.14. Silence of Specifications**

THE APPARENT SILENCE OF SPECIFICATIONS AS TO ANY DETAIL OR TO THE APPARENT OMISSION FROM IT OF A DETAILED DESCRIPTION CONCERNING ANY POINT, SHALL BE REGARDED AS MEANING THAT ONLY THE BEST COMMERCIAL PRACTICES ARE TO PREVAIL.

## **2.2. Submittal Instructions**

### **2.2.1. Solicitation Review**

Please carefully review all information contained in the Event, including all documents available as attachments or available through links. Any difficulty accessing the documents or opening provided links or documents should be reported immediately to the Issuing Officer (Section 1.4).

### **2.2.2. Preparing a Response to The Solicitation**



1. The BWW will not be responsible for the supplier's misunderstanding of the scope of work or any terms and conditions of the solicitation. The BWW will not be responsible for oral interpretations of this solicitation. Supplier's questions and/or comments concerning lack of clarity, defects and questionable or objectionable material in the solicitation must be submitted in writing to and received by the Issuing Officer, or their designee, no later than the deadline for questions date noted on the Schedule of Events (Section 1.3). Questions must specify the Section(s), paragraph(s), and page number(s) to which the question refers.
2. Use the BWW provided worksheets to prepare your response. Unless otherwise directed, do not insert "see attached document" (or similar statements) in the worksheet to reference separate documents. Please review and confirm that the most competitive response has been provided.
3. Answer each question in sufficient detail for evaluation while using judgment with regards to the length of response.
4. Proofread your response and make sure it is accurate and readily understandable.
5. Label any and all documents using the corresponding section numbers of the solicitation or any other logical name so that the BWW can easily organize and navigate the supplier's response

### **3. Instructions to Suppliers**

This section contains general business requirements. By submitting a response, the supplier is certifying its agreement to comply with all of the identified requirements of this section and that all costs for complying with these general business requirements are included in the supplier's submitted Cost Worksheet.

#### **3.1. Standard Insurance Requirements and Bonding Insurance**

Suppliers shall not commence any work until all the insurance as provided herein is obtained nor until the BWW has approved such insurance. Certificates issued by the Supplier's Insurance Company must be filed with the BWW before any work is commenced as evidence of the insurance as provided herein. Such certificates must contain a clause stating that the Insurance Company will notify the BWW ten days prior to any change, cancellation, or renewal of the Supplier's insurance.

1. **Workmen's Compensation Insurance:** The Supplier shall carry Workmen's Compensation Insurance during the life of the Contract to insure statutory liability to their employees.
2. **Comprehensive General Liability and Property Damage:** The Supplier shall carry Comprehensive General Liability and Property Damage Insurance during the life of the contract covering all of the Supplier's own operations. The limits shall not be less than \$1,000,000 for bodily injury and \$500,000 for property damage.
3. **Comprehensive Automobile Liability and Property Damage:** The Supplier shall carry Comprehensive Automobile Liability and Property Damage Insurance during the life of the contract covering supplier's own automobile equipment and if any, supplier hired and non-supplier owned vehicles. The limits shall not be less than \$100,000 for each person, \$300,000 each accident for bodily injury, and \$100,000 for property damage.

#### **Bonding**

1. **Bid Bond.** An original bid bond is not required

#### **3.2 Proposal Certification**

By responding to this solicitation, the supplier understands and agrees to the following:



1. That the submitted Cost Worksheet constitutes an offer, which if accepted in writing by the BWW, and subject to the terms and conditions of such acceptance, will constitute a valid and binding contract between the supplier and the BWW; and
2. That the supplier guarantees and certifies that all items included in the supplier's response meet all of the solicitation's identified specifications and requirements except as expressly stated otherwise in the supplier's response; and
3. That the response submitted by the supplier shall be valid and held open for a period of **ninety (90) days** from the final solicitation closing date and that the supplier's offer may be held open for a lengthier period of time subject to the supplier's consent; and
4. That the supplier's response is made without prior understanding, agreement, or connection with any corporation, firm, or person submitting a response for the same materials, supplies, equipment, or services and is in all respects fair and without collusion or fraud. Supplier understands and agrees that collusive bidding is a violation of state and federal law and can result in fines, prison sentences, and civil damage awards; and
5. That any provision of the State of Alabama Code has not been violated and will not be violated in any respect.

#### **4. Solicitation Bid Factors**

This section contains the detailed technical requirements and related services for this solicitation. The BWW has determined that it is best to define its own needs, desired operating objectives, and desired operating environment. The BWW will not tailor these needs to fit a particular solution a supplier may have available; rather, the suppliers shall propose to meet the BWW's needs as defined in this solicitation. All claims shall be subject to demonstration. Suppliers are cautioned that conditional responses/bids, based upon assumptions, may be deemed non-responsive.

Unless requested otherwise, all responses must be provided within the provided forms included with this solicitation.

##### **4.1. Introduction**

All of the items described in this section are service levels and/or terms and conditions that the BWW expects to be satisfied by any awarded supplier. Each supplier must indicate its willingness and ability to satisfy these requirements in the supplier's submitted response.

Unless otherwise specified, references to brand name or trade name/mark products are intended to be descriptive, but not restrictive, and are used to indicate the quality and characteristics of products that may be offered. Other products may be considered for award if such products are clearly identified and are determined by the BWW to meet its needs in all respects. Each supplier's response must indicate the brand name, model, and/or series number of the product offered and include such specifications, catalog pages, or other data that will provide an adequate basis for determining the quality and functional capabilities of the product offered.

##### **4.2. Mandatory Requirements**

As noted in the preceding section, this solicitation contains mandatory requirements (e.g., product specifications, service or quality levels, staff requirements, experience, or license requirements, etc.) which must be met by the supplier in order for the supplier to be considered "responsive" and, therefore, eligible for contract award. These mandatory requirements will be defined in one or more of the following ways:

1. Requirements in this solicitation document





2. Requirements contained in any attachment to this solicitation, such as HUB Documents, EEO Report, Certification of Non- Discrimination, Debarment Form, any BWW requested bonds, and the Cost Worksheet

## 5. Cost Worksheet

Each supplier is required to submit pricing as part of their response.

### 5.1. General Pricing Rules

By submitting a response, the supplier agrees that it has read, understood, and will abide by the following instructions/rules:

1. The submitted pricing must include all costs of performing pursuant to the resulting contract; and
2. Bids containing a minimum order/ship quantity or dollar value, unless otherwise called for in the solicitation, will be treated as non-responsive and may not be considered for award; and
3. The supplier is required to provide net prices. In the event there is discrepancy between a supplier's unit price and extended price, the unit price shall govern;
4. The prices quoted and listed in the response shall be firm throughout the term of the resulting contract, unless otherwise noted in the solicitation or contract; and
5. Unless otherwise specified in any terms and conditions issued by the BWW to the solicitation, all product deliveries will be F.O.B. destination and all shipping charges must be included in the quoted cost; and
6. Unless expressly permitted by the solicitation, responses containing provisions for late or interest charges will not be awarded a contract. Suppliers must "redact" any such provisions in their submitted forms; and
7. Responses containing prepayment and/or progress payment requirements may be determined non-responsive unless otherwise permitted by the solicitation; and
8. Unless permitted by the solicitation, responses requiring payment from the BWW in less than thirty (30) days will be considered non-responsive; and
9. The BWW is exempt from certain taxes and no provision for such taxes should be included in the supplier's response.

### 5.2 Cost Structure and Additional Instructions

BWW's intent is to structure the cost format in order to facilitate comparison among all suppliers and foster competition to obtain the best market pricing. Consequently, the BWW requires that each supplier's cost be structured as directed in the solicitation. Additional alternative cost structures will not be considered. Each supplier is hereby advised that failure to comply with the solicitation instructions, submission of an incomplete offer, or submission of an offer in a different format than the one requested may result in the rejection of the supplier's response.

Enter all information directly into the Cost Worksheet(s). Enter numbers on each cost sheet in "number" (two-place decimal), not "currency" or other format unless otherwise stated. That is, omit dollar signs, commas, and any other non-essential symbols. (e.g., \$7.90 should be entered as 7.90) Prices must be in US Dollars. Enter "n/a" to indicate not available or "0" if there is no charge. Cells left blank will be interpreted as "no offer".

## 6. Evaluation and Award

All timely responses will be evaluated in accordance with the following steps. The objective of the evaluation process is to identify the most competitive bid. Once the evaluation process has been completed, the apparent



successful supplier(s) will be required to enter into discussions with the BWW to resolve any exceptions to BWW's contract.

#### **6.1. Administrative/Preliminary Review**

First, the responses will be reviewed by the Issuing Officer, or their designee, to determine compliance with the following requirements:

1. Response was submitted by deadline
2. Response is complete and contains all required documents

#### **6.2. Evaluating Bid Factors**

If the supplier's response passes the Administrative/Preliminary Review, the supplier's responses will be evaluated. Responses to mandatory requirements will be evaluated on a pass/fail basis. If a response fails to meet a mandatory requirement, the BWW will determine if the deviation is material. A material deviation will be cause for rejection of the response. An immaterial deviation will be processed as if no deviation had occurred.

#### **6.3. Evaluating Cost**

BWW may utilize lowest cost, lowest total cost, and total cost of ownership (TCO) or greatest savings to determine the most competitive pricing. Submitted pricing may be evaluated/scored on an overall basis or at the category/subcategory/line level (as applicable) relative to other responses/bids.

#### **6.4. Local Preference**

BWW may choose to utilize a local preference for the award of a contract for items of personal property or services as provided by and in accordance with State of Alabama Code §41-16-50 of the Code of Alabama (1975). A local preference is not applicable to the award of a contract funded by federal grant. Per State of Alabama Code § 41-16-50, the BWW considers Blount, Jefferson, St. Clair, and Shelby Counties to be within its Core Based Statistical Area.

#### **6.5. Alabama Based In-State Preference**

In compliance with State of Alabama Code § 41-16-57(b), the purchase of or contract for goods or services, the BWW shall give preference, provided there is no sacrifice or loss in price or quality, to commodities produced in Alabama or sold by Alabama persons, firms, or corporations.

#### **6.6. Selection and Award**

It is likely that this solicitation may result in multiple awards determined by pricing and availability. Any contract award(s) resulting from the solicitation will be made to the lowest, responsive and responsible supplier(s) meeting all specifications and with whom the BWWB has reached agreement on all contract terms and conditions. The BWWB reserves the right to select one or more suppliers for award by way of awarding all items to one supplier, individual line items to one or more suppliers, or subcategories of products/services to one or more suppliers when to do so is in the best interests of the BWWB.

When selecting the lowest responsive and responsible supplier, the determination may involve all or some of the following factors: price, conformity to specifications, financial ability to meet the contract, previous performance, facilities and equipment, availability of repair parts, experience, delivery promise, terms of payments, compatibility as required, other costs, and other objective and accountable factors which are reasonable.



### **6.7. Site Visits and Oral Presentations**

The BWW reserves the right to conduct site visits, request product/work samples, or to invite suppliers and/or awarded suppliers to present their product/service solution to the evaluation teams. The supplier(s) and/or awarded supplier(s) shall provide access to all manufacturer's production, testing, storage, operation, and other areas if, and when, requested by the BWW.

## **7. Solicitation Terms and Conditions**

The contract that the BWW expects to award as a result of this solicitation will be based upon the solicitation, the successful supplier's final response as accepted by the BWW and the contract terms and conditions. The "successful supplier's final response as accepted by the BWW" shall mean: the response submitted by the awarded supplier, written clarifications, and any other terms deemed necessary by the BWW, except that no objection or amendment by a supplier to the solicitation requirements or the contract terms and conditions shall be incorporated by reference into the contract unless the BWW has explicitly accepted the supplier's objection or amendment in writing.

### **Exception to Terms and Conditions**

By submitting a response, each supplier acknowledges its acceptance of the solicitation specifications without change except as otherwise expressly stated in their submitted responses. If a supplier takes exception to a solicitation provision, the supplier must state the reason for the exception and state the specific language it proposes to include in place of the provision. Any exceptions to any solicitation specification must be redlined with comments or countered as requested by other BWW supplied documentation, explaining the rationale for the proposed revision and submitted as an attachment to the supplier's response. Proposed exceptions must not conflict with or attempt to preempt mandatory requirements specified in the solicitation. Proposed exceptions must be in compliance with State of Alabama law. For further information regarding contracting with BWW, please go to the [State of Alabama Legislature Webpage](#), select [Legal Resources](#), and then [Code of Alabama](#).

In the event the supplier is selected for potential award, the supplier will be required to enter into discussions with the BWW to resolve any contractual differences before an award is made. These discussions are to be finalized and all exceptions resolved within the period of time identified in the schedule of events. Failure to resolve any contractual issues will lead to rejection of the supplier's response. The BWW reserves the right to proceed to discussions with the next best ranked supplier.

Exceptions that materially change the terms or the requirements of the solicitation may be deemed non-responsive by the BWW, in its sole discretion, and rejected. Contract exceptions which grant the supplier an impermissible competitive advantage, as determined by the BWW, in its sole discretion, will be rejected. If there is any question whether a particular contract exception would be permissible, the supplier is strongly encouraged to inquire via written question submitted to the Issuing Officer prior to the deadline for submitting written questions as defined by the Schedule of Events.

## **8. Delivery and Invoicing**

### **Delivery of Products and/or Services**

Unless otherwise stated in the solicitation and any resulting contract, items shall be shipped F.O.B. Destination. The supplier shall retain title for the risk of transportation, including the filing for loss or damages. The invoice covering the items is not payable until items are delivered and accepted by BWW. Unless the F.O.B. clause states otherwise, the seller assumes transportation and related charges either by payment or allowance.

All items shall be subject to inspection on delivery. Hidden damage will remain the responsibility of the awarded supplier to remedy without cost to the BWW, regardless of when the hidden damage is discovered.



**F.O.B. Birmingham Water Works  
3600 First Avenue North  
Birmingham, AL 35222**

The BWW reserves the right to have orders delivered to different locations that are BWW owned or leased, or contractor worksites at the awarded supplier's expense.

A packing list shall accompany every shipment. The absence of a packing slip or required shipping order information may cause refusal of the shipment. The packing list shall contain: Purchase Order number, Delivery release number, item description, quantity shipped, quantity ordered, and quantity backordered (if any).

If there is a delay in products manufacturing or shipping and/or the performance of services, the awarded supplier(s) must notify the BWW, in writing, as soon as possible. The awarded supplier(s) must provide weekly updates, in writing, to the BWW for any product and/or service delays.

#### **Invoicing**

The BWW will render payment to the awarded supplier(s) by check on a net 30-day basis after receipt of the products and/or services and an invoice that has been submitted as required in this solicitation, unless the BWW authorizes alternative terms in writing. All invoices must be submitted to [accountspayable@bwwb.org](mailto:accountspayable@bwwb.org). Any discrepancies noted by the BWW must be corrected by the awarded supplier within 48 hours. The payment amount due on invoices cannot be altered by the BWW personnel. Once disputed items are resolved, the awarded supplier must submit an amended invoice, or a credit memorandum for the disputed amount. The BWW will not make partial payments on an invoice where there is a dispute. The BWW will only make payments on authorized transactions.

Invoices submitted pursuant to this solicitation must include:

- Name and remittance address of supplier.
- Invoice date.
- Invoice number.
- Solicitation number.
- BWW Issued PO number.
- Must clearly show the description of products and/or services to include the number of each product or line item fulfilled.
- Contact information of the person to be notified in event of a discrepancy in the invoice.

#### **9. Order of Preference**

In the case of any inconsistency or conflict among the specific provisions of the executed contract (including any amendments accepted by both the BWW and the Awarded Supplier), the solicitation (including any subsequent addenda and written responses to supplier's questions), and the supplier's response, any inconsistency or conflict shall be resolved as follows:

- (i) First, by giving preference to the specific provisions of the executed contract.
- (ii) Second, by giving preference to the specific provisions of the solicitation.
- (iii) Third, by giving preference to the specific provisions of the supplier's response, except that objections or amendments by a supplier that have not been explicitly accepted by the BWW in writing shall not be included in the contract and shall be given no weight or consideration.

#### **10. Indemnification**

The successful bidder shall indemnify and hold harmless the Board and its present and future affiliates, and the representatives, agents, officers, and employees of each of them (The "Indemnified Parties") from and against



any and all loss, damage, or liability resulting from demands, claims, suits, or actions of any character presented or brought for any injuries (including death) to persons (including without limitation employees or agents of the successful bidder) and for damages to property caused by or arising out of any negligent (including strict liability), wanton, or intentional act or omission of the successful bidder, any of its subcontractors, anyone directly or indirectly employed by any of them or anyone whose actions anyone of them may be liable or in any way associated or connected with the performance of the obligations under these specifications, in whatever manner the same may be caused, and whether or not the same be caused or arise out of the joint, concurrent or contributory negligence of any of the Indemnified Parties. The preceding indemnity shall include, but not be limited to, court costs, reasonable attorney's fees, investigation costs, defense costs, settlements, and judgments associated with such demands, claims, suits, or actions.

The Board shall not be liable for, and the successful bidder shall waive all claims against the Board and be responsible for, all loss or damage to persons or property sustained by the successful bidder, its officers, agents, or employees (except such as may arise because of the sole negligence of the Board) which may arise about the services to be performed by the successful bidder hereunder.

#### **11. Governing Law**

All contracts entered into as a result of this solicitation shall be governed by and construed in accordance with the substantive laws of the State of Alabama.

#### **12. List of solicitation Attachments**

The following documents make up this solicitation. Any difficulty locating or accessing the following documents should be immediately reported to the Issuing Officer.

- A. BWW Main Solicitation Document (This Document)
- B. Cost Worksheet(s)
- C. All HUB Related Documents (Each HUB Document is Labeled as a HUB Document)
- D. Non-Discrimination Policy
- E. Conflict of Interest Form
- F. EEO Report
- G. Supplier Information Form
- H. Supplier Diversity Questionnaire
- I. Debarment Form
- J. Receipt of Bid Package Form

# Appendix A

## **SPECIFICATIONS AND TERMS FOR CURB BOXES AND LIDS**

### **Specifications**

- Curb boxes shall be City of Birmingham patterns.
- Drawings for boxes required are attached and covers must be in compliance with same.
- Length of top section shall be 12" to 14".
- Length of bottom section shall be 14".
- Lids for above curb boxes shall be marked "Water".
- Extension of curb boxes shall be 12" and 18" in length.
- Cast iron shall conform to A.S.T.M. Specifications A-48 for Class 20 gray iron castings or latest revision thereof.
  - All castings shall be true and free of holes; and
  - They shall be cleaned according to good foundry practice, chipped and ground as needed to remove fins and rough places on castings; and
  - The castings shall be coated with a coal tar paint that is applied cold and be smooth and not brittle or sticky at any temperatures; and
  - Coatings shall conform to AWWA Specifications C 104-53 or latest revision thereof.
- In the interest of standardization, curb boxes shall be as those manufactured by Opelika Foundry, Bingham & Taylor or approved equal and must be interchangeable with those existing in our system.

**When reference is made in these specifications to American Water Works Association (AWWA), American National Standards Institute (ANSI), American Society for Testing and Materials (ASTM), American Iron and Steel Institute (AISI), American Society of Safety Engineers (ASSE), or other standards, it is understood that the latest revision thereof shall apply. The manufacturer should especially note that this part of the specifications applies to all items.**

### **Terms**

- All above items must be shipped in crates or pallets on a flatbed truck; and
- Individual crates, pallets, bundles or packages must not exceed 2,500 lbs. each.

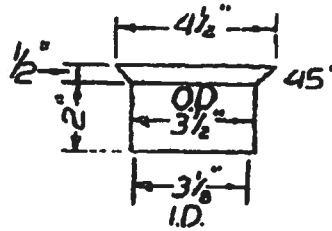
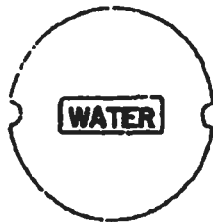
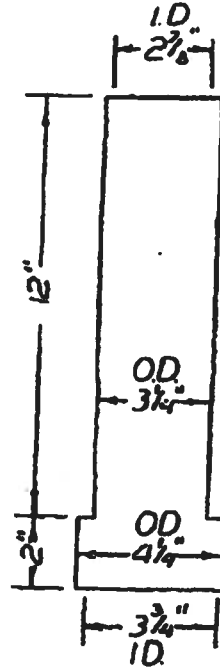
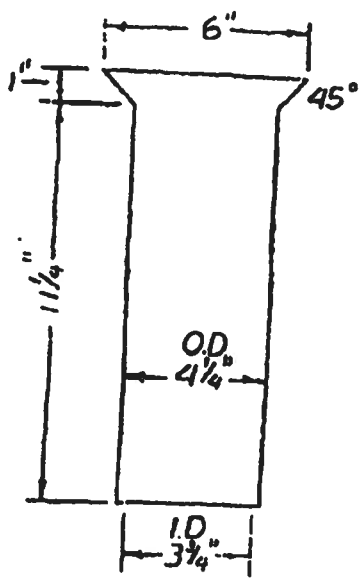

**BIRMINGHAM CURB BOX**

THE WATER WORKS BOARD OF THE CITY OF BIRMINGHAM

SEC. \_\_\_\_\_ AP. \_\_\_\_\_ SCALE  $\frac{1}{4}":1'-0"$  WO. \_\_\_\_\_ DATE 5-1-75 DRAWN BY 12: E.



# **SPECIFICATIONS AND TERMS FOR VALVE BOXES AND VALVE BOX EXTENSIONS**

## **Specifications**

- Valve boxes shall be of cast iron, two-piece, screw type, 5-1/4" diameter and extend 24" - 36" with a minimum weight of 80 pounds.
- Top sections for valve boxes described above shall be 15" and have a minimum weight of 29 pounds.
- Bottom sections for valve boxes described above shall be 24" long and have a minimum weight of 33 pounds.
- Covers for valve boxes shall be marked "Water" and have a sta-put skirt and have a minimum weight of 14 pounds.
- Extension of valve boxes shall be 12" and 18" in length.
- Drawings for above required valve boxes and extensions are attached.
- Cast iron shall conform to A.S.T.M. Specifications A-48 for Class 20 gray iron castings or latest revision thereof.
  - All castings shall be true and free of holes; and
  - They shall be cleaned according to good foundry practice, chipped and ground as needed to remove fins and rough places on castings; and
  - The castings shall be coated with a coal tar paint that is applied cold and be smooth and not brittle or sticky at any temperatures; and
  - Coatings shall conform to AWWA Specifications C 104-53 or latest revision thereof.
- In the interest of standardization, curb boxes shall be as those manufactured by Opelika Foundry, Bingham & Taylor or approved equal and must be interchangeable with those existing in our system.

**When reference is made in these specifications to American Water Works Association (AWWA), American National Standards Institute (ANSI), American Society for Testing and Materials (ASTM), American Iron and Steel Institute (AISI), American Society of Safety Engineers (ASSE), or other standards, it is understood that the latest revision thereof shall apply. The manufacturer should especially note that this part of the specifications applies to all items.**

## **Terms**

- All above items must be shipped in crates or pallets on a flatbed truck; and
- Individual crates, pallets, bundles or packages must not exceed 2,500 lbs. each.

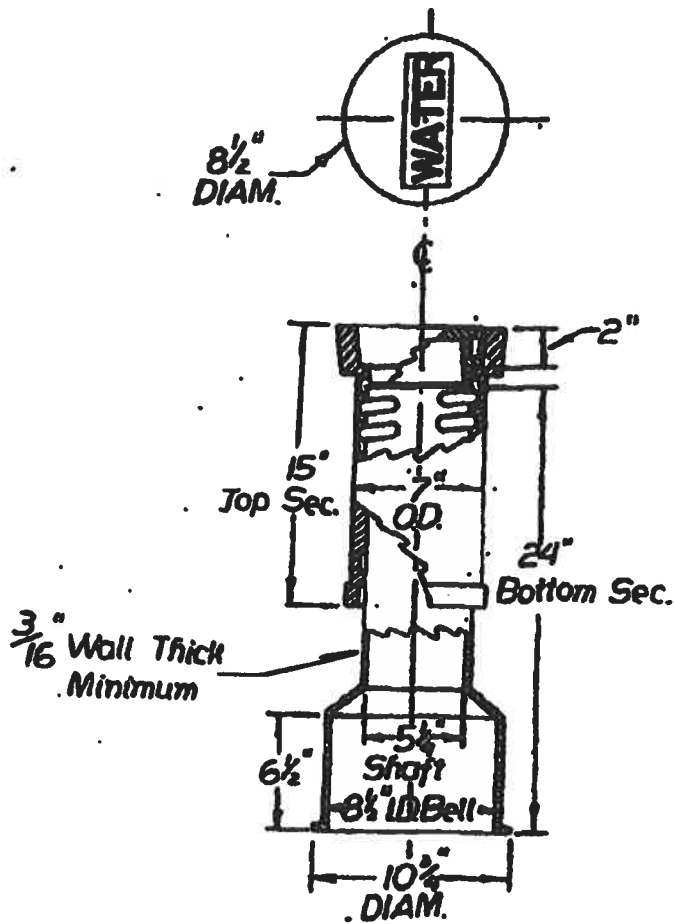

NO. 20 5 1/4"  
**Screw Type Valve Box**  
 FOR VALVES UP TO 12" IN SIZE.  
 EXTENSION 24" TO 36"

# VALVE BOX EXTENSION

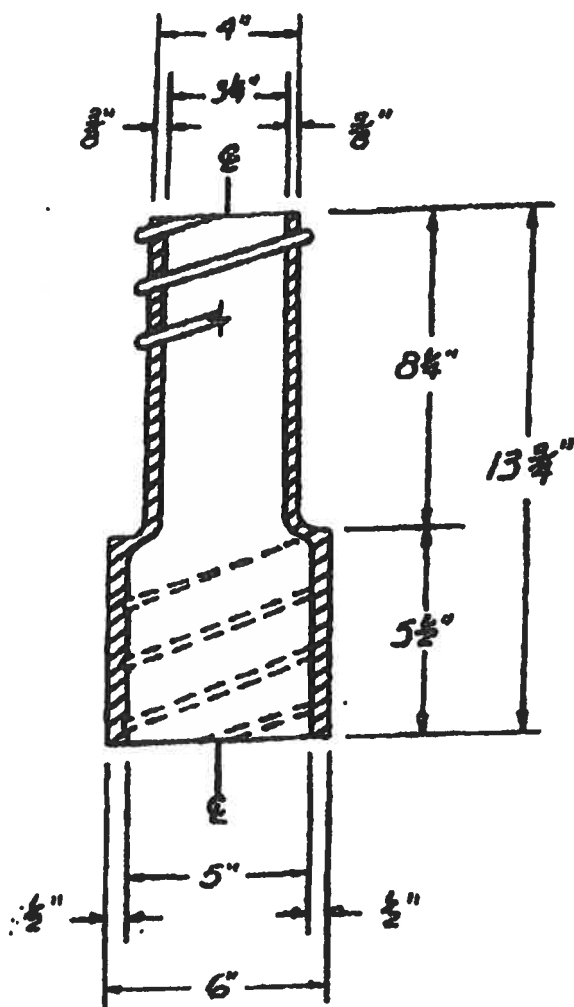

THE WATER WORKS BOARD OF THE CITY OF BIRMINGHAM

SCALE 3" = 1'-0" W.D. DATE 11-16-57 DESIGNED BY T. Murphy

# **SPECIFICATIONS AND TERMS FOR PAVADJUSTERS AND LIDS**

## **Specifications**

- Pavadjusters and Lids must be the 'round" type without lips or flanges.
- They shall be cast from Class 20-A iron, ASTM Specifications A-48.75, Federal Specifications Q.Q.F.-652A.
- All parts shall be bituminous coated.
- In the interest of standardization, all proposed pavadjusters and lids must be cast to the dimensions shown on the attached drawing and must be inter-changeable with those existing in our system.
- Drawings for pavadjusters are attached.
- Domestic manufacturing required

**When reference is made in these specifications to American Water Works Association (AWWA), American National Standards Institute (ANSI), American Society for Testing and Materials (ASTM), American Iron and Steel Institute (AISI), American Society of Safety Engineers (ASSE), or other standards, it is understood that the latest revision thereof shall apply. The manufacturer should especially note that this part of the specifications applies to all items.**

## **Terms**

- All above items must be shipped in crates or pallets on a flatbed truck; and
- Individual crates, pallets, bundles or packages must not exceed 2,500 lbs. each.

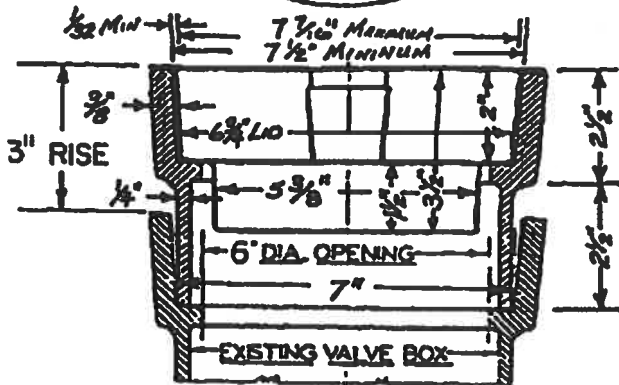
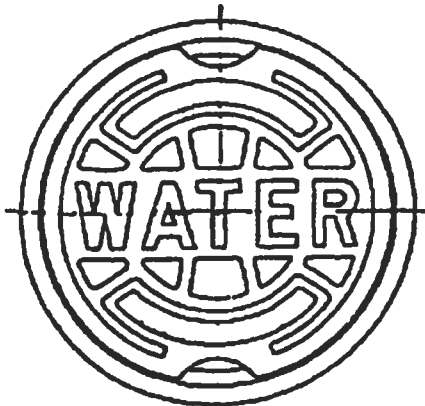

3"  
PAVADJUSTER

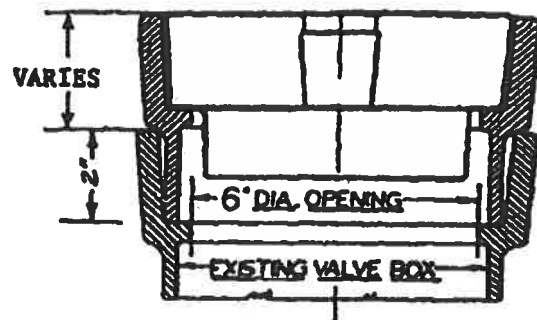
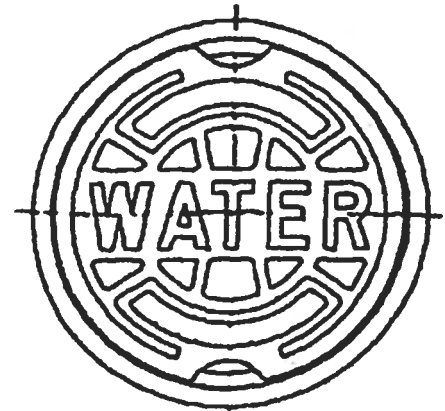

VARIES  
1, 1 1/2, 2, 2 1/2"  
PAVADJUSTER

NOTE: All dimensions are nominal except as specified.



PAV. ADJUSTER

DRAWN BY: KT  
 CHECKED BY:  
 APPROVED BY:  
 ENGINEER:  
 WORK ORDER:  
 DATE: 11/30/09  
 D.P.  
 SEC.  
 SCALE: NTS  
 FILE:

**Cost Worksheet**  
 Submission No. 24-027  
 Birmingham Water Works Board

Offeror must provide their cost information in this spreadsheet. Failure to complete this spreadsheet will result in disqualification of the your submission response. The Offeror's figure submitted below must include all costs associated with and in support for the procurement of all commodities and/or services.

Offeror must indicate the "Cost Worksheet" as part of the response. The Cost Worksheet will be evaluated in accordance with the solicitation documentation.

| Description                 | Estimated Yearly Quantity | Brand | Model | Where are your Manufacturing facilities in North America? If you are a distributor, you must reference the locations that produce the products associated with this submission. | Within the Past Three Years have any of your Manufacturing Facilities? If you are a distributor you must reference the locations that produce the products associated with this submission. | Delivery Time-Frame (Day) of an Order After Receipt of MWB's Issued PO. This shall be considered a Firm Time. You must respond with a period of day (Example- 40 Day), Weeks or Varying Time-Frame are Not Acceptable Answers. | Warranty Period Upon Date of Issued Commodity | Cost Per Each | Total Line Cost |
|-----------------------------|---------------------------|-------|-------|---|---|--|---|---------------|-----------------|
| 1 Curb Box - Lid Only       | 100.00                    |       |       |   |   |  |   | \$            | -               |
| 2 Curb Box - Top Section    | 100.00                    |       |       |   |   |  |   | \$            | -               |
| 3 Curb Box - Bottom Section | 100.00                    |       |       |   |   |  |   | \$            | -               |
| 4 Value Box- Lid Only       | 800.00                    |       |       |   |   |  |   | \$            | -               |
| 5 Value Box-Top Section     | 900.00                    |       |       |   |   |  |   | \$            | -               |
| 6 Value Box- Bottom Section | 850.00                    |       |       |   |   |  |   | \$            | -               |
| 7 Pavedjester 1"            | 450.00                    |       |       |   |   |  |   | \$            | -               |
| 8 Pavedjester 1.5"          | 310.00                    |       |       |   |   |  |   | \$            | -               |
| 9 Pavedjester 2"            | 210.00                    |       |       |   |   |  |   | \$            | -               |
| 10 Pavedjester 2.5"         | 50.00                     |       |       |   |   |  |   | \$            | -               |
| 11 Pavedjester 3"           | 50.00                     |       |       |   |   |  |   | \$            | -               |
| <b>TOTAL COST</b>           |                           |       |       |   |   |  |   |               | \$              |

Company Name: \_\_\_\_\_  
 Printed Name and Title of Person Signing: \_\_\_\_\_  
 Authorized Signature: \_\_\_\_\_  
 Date: \_\_\_\_\_

This form must be completed in its entirety by the Offeror and posted as required in the solicitation.

**HUB FORM ONE**  
**(HUB Program Acknowledgment)**

The Water Works Board of the City of Birmingham ("BWVB") has initiated a program to encourage the participation of HUB companies (as that term is defined in the HUB Program) on BWVB' s Goods and services/Public works bids. This signed statement serves as an acknowledgment by the undersigned bidder/Prime company that it fully understands and will voluntarily participate in and follow the guidelines and instructions included in the BWVB HUB Program.

Company: \_\_\_\_\_

Submitted By (Print Name and Job Title): \_\_\_\_\_

\_\_\_\_\_  
Signature: \_\_\_\_\_

**HUB FORM TWO**  
**(HUB Program Compliance Instructions)**

Please submit the following with the HUB COMPLIANCE FORM:

- I. List of all committed and uncommitted subcontractors by trade, including\_ company name, address, telephone number, contact person, dollar amount of subcontract, and HUB status. Indicate in writing if no solicitations were made because the contractor intends to use only its own forces to accomplish the work.
- II. Proof of HUB certification for each subcontractor listed as a HUB.
- III. Documentation of solicitation effort for prospective HUB firms, such as fax confirmation sheets, copies of solicitation letters/emails, printout of the online solicitations, printouts of online search results, affidavits of publication in newspapers, etc. The prime contractor is strongly encouraged to follow up each written, fax, or email solicitation with at least one logged phone call.
- IV. Justification for not selecting a certified HUB subcontractor that submitted a low bid for any subcontract area.
- V. HUB Form 5 - HUB Subcontractor Performance Form.
- VI. HUB Form 6 - HUB Subcontractor Utilization Form.



**HUB FORM TWO**

**HUB Compliance Form**

ALL INFORMATION OUTLINED ON THIS FORM IS REQUIRED FOR HUB COMPLIANCE. THE PROPOSED BIDDER/PRIME COMPANY SHOULD ENSURE THAT THIS INFORMATION IS COMPLETE **PRIOR** TO SUBMITTAL.

**CERTIFICATIONS:**

I certify that the information submitted on and with this form is true and accurate and that this firm has met and will continue to meet the conditions of this contract regarding HUB solicitation and utilization. I further certify criteria used in selecting sub-companies and suppliers were applied equally to all potential participants and that HUB Sub-company Participation Form (HUB Form 4) and HUB Sub-company Performance Form (HUB Form 5) were distributed to all HUB contractors.

Bidder/Prime Company:

---

Bidder/Prime Company (Printed- Authorized Signing Agent Name and Title):

---

Authorized Signature and Date:

---

**GENERAL INFORMATION**

Owner's Name:

---

Owner phone number/email:

---

Bidder/prime company:

---

Bidder/prime company Point of Contact:

---

Bidder/prime phone number/email:

---

Bidder/prime company total bid amount:

\$ \_\_\_\_\_

Proposed HUB Sub-company participation amount: \$ \_\_\_\_\_ Percentage: \_\_\_\_\_%

**HUB FORM 6 (GOODS AND SERVICES)**  
**DIRECT MANUFACTURER/SUPPLIER CERTIFICATION**

I/we hereby certify that we are direct manufacturers or suppliers of the goods or services sought in this Bid and have no distributors, wholesalers, retailers or other intermediaries, and thus do not have any opportunities for HUB participation in this Bid.

|                  |  |                   |  |
|------------------|--|-------------------|--|
| Bidder Name      |  | Bid/Contract Name |  |
| Bid/Proposal No. |  | Point of Contact  |  |
| Address          |  |                   |  |
| Telephone No.    |  | Email Address     |  |

Please use the space below to explain the details about your business and why there are no HUB opportunities for your bid:

---

---

---

---

---

---

---

---

---

---

---

---

---

---

---

---

---

---

---

---

---

---

---

---

|                         |                   |
|-------------------------|-------------------|
| <b>Bidder Signature</b> | <b>Print Name</b> |
|                         |                   |
| <b>Title</b>            | <b>Date</b>       |
|                         |                   |



## **NON-DISCRIMINATION POLICY**

The Birmingham Water Works Board (BWWB) values the diversity of the people with whom we work and the contributions they make. Accordingly, the BWWB is committed to providing an inclusive and welcoming environment for all members of our staff, clients, volunteers, independent contractors, and vendors.

The BWWB is an equal opportunity employer and all decisions regarding recruiting, hiring, promotion, assignment, training, termination, selection of volunteers and vendors, and other terms and conditions of employment will be made without consideration of age, sex, race, color, religion, gender, gender identity or expression, national origin, sexual orientation, disability, marital status, veteran status, pregnancy status, political opinion, work-related injury, or any other factor, characteristic or trait protected by applicable national, state or local laws.

Members of our community are encouraged to raise concerns or make complaints regarding discrimination or harassment under this policy without the fear of retaliation. It is a violation of BWWB policy to retaliate against an individual for raising a good-faith concern regarding workplace discrimination or harassment; filing a complaint for discrimination or harassment; or, for cooperating in an investigation of alleged discrimination or harassment. Any person found to be in violation of this policy is subject to disciplinary action.

Discrimination, harassment, disrespectful or inappropriate behavior, unfair treatment or retaliation of any kind will not be tolerated. This policy applies not only to BWWB employees but also to the volunteers, independent contractors, and business partners with whom we work. BWWB employees, volunteers, independent contractors, and other constituents, whenever and wherever those individuals are conducting BWWB business or participating in BWWB events or activities, shall maintain an environment free of discrimination, harassment, and retaliation.

Any employee who has a question or concern regarding any type of discrimination or harassment is encouraged to bring it to the attention of his/her manager or the Human Resources Department.

Vendor agrees and warrants that contractor does not discriminate or permit discrimination against any employee or applicant for employment on the grounds of race, color, religion, gender, sexual orientation, gender identity or national origin.



**NON-DISCRIMINATION POLICY**

Executed

Contractor's Name: \_\_\_\_\_

Authorized Signature: \_\_\_\_\_

Printed Name and Title of Person Signing:

\_\_\_\_\_

Date Signed: \_\_\_\_\_



## FUNDS PAID AND CONFLICT OF INTEREST AGREEMENT

This Funds Paid and Conflict of Interest Agreement (“Agreement”) is made a part of, and Contractor affirms, acknowledges, and agrees, that its terms and conditions are part of that certain agreement already entered into between the Water Works Board and \_\_\_\_\_ (Supplier). The Contractor further affirms that the terms and conditions of the Agreement shall be deemed incorporated into and a part of the Original Agreement as if said terms and conditions were originally set forth in the Original Agreement.

**FUNDS PAID:** Contractor and the Contractor representative(s) signed below certify under penalty of perjury by the execution of this Agreement that no part of the funds paid by the Water Works Board pursuant to this Agreement nor any part of the services, products or any item or thing of value whatsoever purchased or acquired with said funds shall be paid to, used by or used in anyway whatsoever for the personal benefit of any member or employee of any government entity whatsoever or family member of any of them, including federal, state, county and municipal and any agency or subsidiary of any such government; and further certify that neither the Contractor nor any of its officers, partners, owners, agents, representatives, employees or parties in interest has in any way colluded, conspired, connived, with anyone or with any member of the governing body or employee of the governing body of the Water Works Board or any other public official or public employee, in any manner whatsoever, to secure or obtain this Agreement and further certify that, except as expressly set out in the scope of work or services of this Agreement, no promise or commitment of any nature whatsoever of anything of value whatsoever has been made or communicated to any such governing body member or employee or official as inducement or consideration for this contract.

Any violation of the terms and scope of services, including misuse of funds provided in this contract shall constitute a breach and default of this Agreement, which shall be cause for termination. Upon such termination of this Agreement due to breach, Contractor shall immediately refund to the Water Works Board all amounts paid by the Water Works Board pursuant to this Agreement.

**CONFLICT OF INTEREST:** The Contractor declares that, as of the date of the Agreement, neither the Water Works Board, nor any of the Water Works Board’s employees or any director nor any other government official is directly or indirectly interested in this Agreement or any agreement with the Contractor for which compensation will be sought during the period of time this Agreement is being performed. And, furthermore, the Contractor pledges that She/he/it will notify the General Manager in writing should it come to his/its knowledge that any such official becomes either directly or indirectly interested in the Agreement or any agreement with the Contractor for which compensation will be sought during the aforesaid period. In addition, the Contractor declares, that as of the date of this Agreement, neither She/he/it nor any of her/his/its officers or employees have given or donated or promised to give or donate, either directly or indirectly, to any official or employee of the Water Works Board, or to anyone else for the Water Works Board’s benefit, any sum of money or other thing of value for aid or assistance in obtaining

this Agreement with the Water Works Board under which compensation will be sought during the period of time this Agreement is being performed. And furthermore, that neither the Contractor nor any of her/his/its officers or employees will give or donate or promise to give or donate, directly or indirectly, to any official or employee of the Water Works Board, or to anyone else for the Water Works Board's, Water Works Board's official, or Water Works Board's employee's benefit, any sum of money or other thing of value, for aid or assistance in obtaining any amendment to this Agreement or any other agreement with the Contractor for which compensation will be claimed during the period of time this Agreement is being performed.

Authorized signature:

Project

Name: \_\_\_\_\_  
(printed)

For: \_\_\_\_\_  
Company Name (printed)

By: \_\_\_\_\_  
Signature of Authorized Representative/Title

Date: \_\_\_\_\_

**(Please return this form with your bid form and/or proposal submittal)**





**BWWB CONTRACTORS EEO REPORT**

1. Select Appropriate Response

**Choose Item**

2. COMPANY NAME, CITY, STATE:

3. BWWB PROJECT/WORK LOCATION (CITY, COUNTY AND STATE)

TABLE A

TABLE B

| JOB CATEGORIES          | TOTAL EMPLOYED |   | TOTAL RACIAL/ETHNIC MINORITY |   | BLACK OR AFRICAN AMERICAN |   | HISPANIC OR LATINO |   | AMERICAN INDIAN OR ALASKA NATIVE |   | ASIAN |   | NATIVE HAWAIIAN OR OTHER PACIFIC ISLANDER |   | TWO OR MORE RACES |   | WHITE |   | APPRENTICES |   | ON THE JOB TRAINEES |   |  |  |
|-------------------------|----------------|---|------------------------------|---|---------------------------|---|--------------------|---|----------------------------------|---|-------|---|---|---|-------------------|---|-------|---|-------------|---|---------------------|---|--|--|
|                         | M              | F | M                            | F | M                         | F | M                  | F | M                                | F | M     | F | M   | F | M                 | F | M     | F | M           | F | M                   | F |  |  |
| OFFICIALS               |                |   |                              |   |                           |   |                    |   |                                  |   |       |   |   |   |                   |   |       |   |             |   |                     |   |  |  |
| SUPERVISORS             |                |   |                              |   |                           |   |                    |   |                                  |   |       |   |   |   |                   |   |       |   |             |   |                     |   |  |  |
| FOREMEN/WOMEN           |                |   |                              |   |                           |   |                    |   |                                  |   |       |   |   |   |                   |   |       |   |             |   |                     |   |  |  |
| CLERICAL                |                |   |                              |   |                           |   |                    |   |                                  |   |       |   |   |   |                   |   |       |   |             |   |                     |   |  |  |
| EQUIPMENT OPERATORS     |                |   |                              |   |                           |   |                    |   |                                  |   |       |   |   |   |                   |   |       |   |             |   |                     |   |  |  |
| MECHANICS               |                |   |                              |   |                           |   |                    |   |                                  |   |       |   |   |   |                   |   |       |   |             |   |                     |   |  |  |
| TRUCK DRIVERS           |                |   |                              |   |                           |   |                    |   |                                  |   |       |   |   |   |                   |   |       |   |             |   |                     |   |  |  |
| IRONWORKERS             |                |   |                              |   |                           |   |                    |   |                                  |   |       |   |   |   |                   |   |       |   |             |   |                     |   |  |  |
| CARPENTERS              |                |   |                              |   |                           |   |                    |   |                                  |   |       |   |   |   |                   |   |       |   |             |   |                     |   |  |  |
| CEMENT MASONS           |                |   |                              |   |                           |   |                    |   |                                  |   |       |   |   |   |                   |   |       |   |             |   |                     |   |  |  |
| ELECTRICIANS            |                |   |                              |   |                           |   |                    |   |                                  |   |       |   |   |   |                   |   |       |   |             |   |                     |   |  |  |
| PIPEFITTERS/PLUMBERS    |                |   |                              |   |                           |   |                    |   |                                  |   |       |   |   |   |                   |   |       |   |             |   |                     |   |  |  |
| PAINTERS                |                |   |                              |   |                           |   |                    |   |                                  |   |       |   |   |   |                   |   |       |   |             |   |                     |   |  |  |
| LABORERS - SEMI SKILLED |                |   |                              |   |                           |   |                    |   |                                  |   |       |   |   |   |                   |   |       |   |             |   |                     |   |  |  |
| LABORERS - UNSKILLED    |                |   |                              |   |                           |   |                    |   |                                  |   |       |   |   |   |                   |   |       |   |             |   |                     |   |  |  |
| <b>TOTAL</b>            |                |   |                              |   |                           |   |                    |   |                                  |   |       |   |   |   |                   |   |       |   |             |   |                     |   |  |  |

|              |  |  |  |  |  |  |  |  |  |  |  |  |  |  |  |  |  |  |  |  |  |  |  |  |
|--------------|--|--|--|--|--|--|--|--|--|--|--|--|--|--|--|--|--|--|--|--|--|--|--|--|
| APPRENTICES  |  |  |  |  |  |  |  |  |  |  |  |  |  |  |  |  |  |  |  |  |  |  |  |  |
| OTJ TRAINEES |  |  |  |  |  |  |  |  |  |  |  |  |  |  |  |  |  |  |  |  |  |  |  |  |

4. PREPARED BY: (Signature and Title of Contractor Representative)

5. DATE

6. REVIEWED BY: (Signature and Title of BWWB Representative)

7. DATE





## Supplier Information Form

1. Name of Company

As Shown On W9 (Line 1)

\_\_\_\_\_

2. Doing Business As

As Shown On W9 (Line 2):

\_\_\_\_\_

3. Mailing Address:

\_\_\_\_\_

4. City: \_\_\_\_\_ State: \_\_\_\_\_ Zip: \_\_\_\_\_

5. Business#: \_\_\_\_\_ Cell#: \_\_\_\_\_

6. Primary Contact Person: \_\_\_\_\_

7. Primary Contact Person Email: \_\_\_\_\_

8. Secondary Contact Person: \_\_\_\_\_

9. Secondary Contact Person Email: \_\_\_\_\_

10. Type of Business: \_\_\_\_\_

11. Federal ID#: \_\_\_\_\_

12. Historically Underutilized Business Status: Choose One

(MUST INCLUDE COPY OF CERTIFICATE FROM CERTIFYING AGENCY)

13. Description of Products and/or Services:

14. COMMENTS:

15. If you are a Prime (General Contractor), Subcontractor or Sub-subcontractor, please provide your Contractor License Number:

General Contractor License #: \_\_\_\_\_

Subcontractor License #: \_\_\_\_\_

Sub-subcontractor License #: \_\_\_\_\_

***The Birmingham Water Works Board  
3600 1<sup>st</sup> Avenue North, Birmingham, AL 35222  
Phone: (205) 244-4300 • Website: [www.bwwb.org](http://www.bwwb.org)***



## Supplier Diversity/Community Involvement Program Questionnaire

Supplier Diversity Program (SDP) promote supplier diversity in public contracting in a manner that develops, strengthens and increases business opportunities for Disadvantaged Business Enterprise (DBE), Minority Business Enterprise (MBE), Women Business Enterprise (WBE), and Veteran Business Enterprise (VBE). Please fill-out the following information on your company's SDP.

1. Supplier Name:

---

2. Contact Person and Title:

---

3. Contact Person's Email:

---

4. Contact Person's Office# :

---

5. Does your company have a Supplier Diversity Program: No

a. If yes, please provide your website or any information pertaining to your SDP.

6. Community involvement is the **power to bring positive, measurable change to both the communities in which you operate and to your business**. Please provide any involvement with the community that your company participates in: Ex: charities, scholarships, etc. (United Way, Salvation Army, Children's Hosp., H2O Foundation, etc.)



**CERTIFICATION REGARDING DEBARMENT**

( \_\_\_\_\_ )  
**Bid Name and Number**

The below-signed Bidder at this moment certifies that it, its officers, directors, owners, stockholders, and its principals:

(i) Are not presently debarred, suspended, proposed for debarment, declared ineligible, or voluntarily excluded from doing business with any Federal department or agency;

(ii) Have not within three years preceding this bid been: debarred, suspended, proposed for debarment, declared ineligible, or voluntarily excluded from doing business with any Federal department or agency; or convicted of or had a civil judgment rendered against them for the commission of fraud or a criminal offense in connection with obtaining, attempting to obtain, or performing a public (Federal, State, or local) transaction or contract; violation of Federal or State antitrust statutes or commission of embezzlement, theft, forgery, bribery, falsification or destruction of records, making false statements, or receiving stolen property; and

(iii) Are not presently indicted for or otherwise criminally or civilly charged by a governmental entity (Federal, State, or local) with the commission of any of the offenses enumerated in paragraph (ii) above.

Executed on this the \_\_\_\_\_ day of \_\_\_\_\_, 20\_\_\_\_.

**BIDDER**

By: \_\_\_\_\_

Its: \_\_\_\_\_

THE STATE OF ALABAMA )

\_\_\_\_\_ COUNTY )

BEFORE ME, a Notary Public in and for said County, in said State, here by certifies that \_\_\_\_\_, whose name as \_\_\_\_\_ of \_\_\_\_\_, a corporation, is signed to the foregoing instrument, and who is known to me, acknowledged that on this day, that being informed of the contents of said instrument, as such officer and with full authority, executed the same voluntarily for and as the act of said corporation.

Given under my hand, this \_\_\_\_\_ day of \_\_\_\_\_, 20\_\_\_\_.

\_\_\_\_\_  
Notary Public  
My commission ends: \_\_\_\_\_

# Receipt of Bid Package

Date/Time Receipt of Response

Bid Name: \_\_\_\_\_

Bid No: \_\_\_\_\_

Issuing Officer: Jonathan Jett

Company: \_\_\_\_\_

Name of Delivery Agent: \_\_\_\_\_

## Signatures

Delivery Agent Signature: \_\_\_\_\_

Purchasing Department Signature: \_\_\_\_\_

**The BWW Purchasing Department shall retain all hard copies of each applicable receipt of bid package(s). The BWW Purchasing Department must have an applicable, executed receipt of bid package per terms and conditions of the applicable solicitation for a potential supplier's bid to be considered responsive, pending evaluation of appropriate staff.**